

HYPERPRO

STEERING DAMPER MOUNTING KIT

for

KTM 790 Adventure R Model 2019->

MK-KT07-0002 PART LIST

SD stroke 68 REVERSED	1	M6x16	2
Damper Clamp [DB0003]	1	M6x35	2
Frame bracket [FRMK47]	1	Washer M6 Ø12	1
Fender bracket [BRKT04]	1	-	-
Spacer [MP-SP061920]	2	-	-
O-ring	1	-	-
M6x12 Button head	2	-	-
M6x20 Low head	1	-	-

ALL IDEAS, DESIGNS ARRANGEMENTS AND PLANS INDICATED OR REPRESENTED BY THIS DRAWING ARE OWNED BY HYPERPRO AND WERE CREATED, EVOLVED AND DEVELOPED FOR USE ON AND IN CONNECTION WITH THE SPECIFIC PROJECT. NONE SUCH IDEAS, DESIGNS, ARRANGEMENTS OR PLANS SHALL BE USED BY OR DISCLOSED TO ANY PERSON, FIRM OR CORPORATION FOR ANY PURPOSE WHATSOEVER WITHOUT THE WRITTEN PERMISSION OF HYPERPRO.

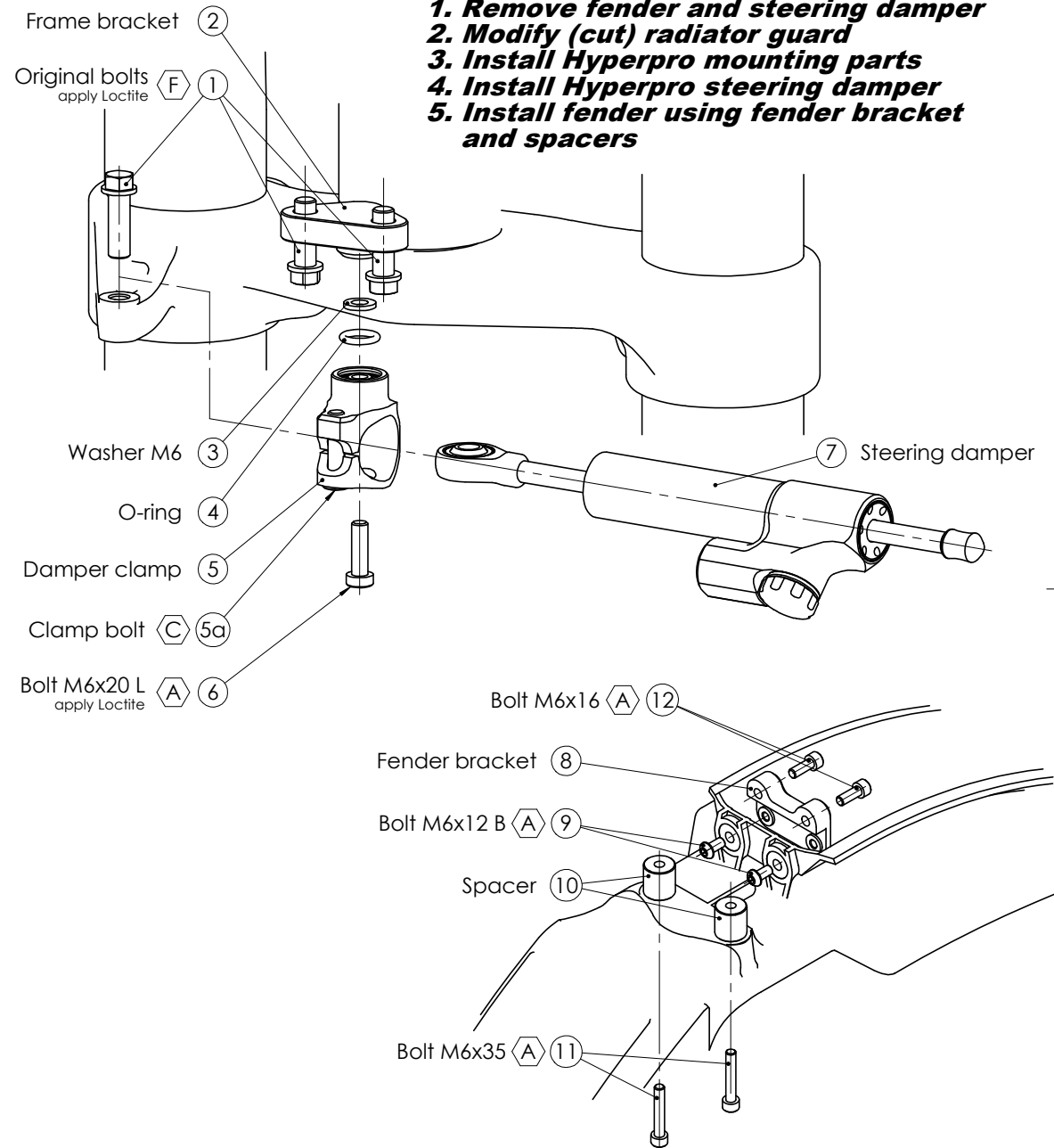
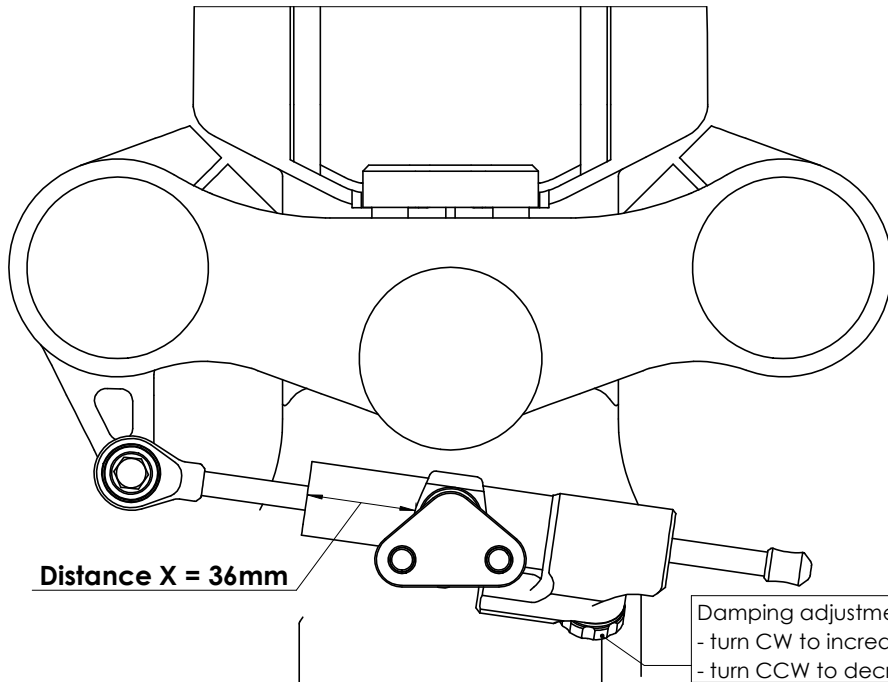

- 1. Remove fender and steering damper**
- 2. Modify (cut) radiator guard**
- 3. Install Hyperpro mounting parts**
- 4. Install Hyperpro steering damper**
- 5. Install fender using fender bracket and spacers**

* TORQUES	
A: 5-9Nm / 44-80Lbs.In / 4.0-6.4Lbs.Ft	D: 8Nm / 70Lbs.In / 5.9Lbs.Ft
B: 14-17Nm / 124-150Lbs.In / 10.3-12.5Lbs.Ft	E: 55Nm / 486Lbs.In / 40Lbs.Ft
C: 6Nm / 53Lbs.In / 4.4Lbs.Ft	F: Factory torque (see owners manual)

HYPERPRO

STEERING DAMPER MOUNTING KIT

for

KTM 790 Adventure R Model 2019->

MK-KT07-0002 INSTALLATION INSTRUCTIONS

In general:

HYPERPRO can not be held responsible in any way for any form of physical, material, financial or other damage arising from use, assembly or overhaul of HYPERPRO products. HYPERPRO reserves the right to make changes without prior notice.

This product is ONLY TO BE INSTALLED BY A PROFESSIONAL MECHANIC.

This product is only to be used for the motorcycle brand, model and year stated specifically on top of the pages of this manual.

DO NOT attempt to install this product on motorcycles from any different brand, model and/or year than stated on the pages of this manual.

DO NOT use this kit for cars, boats, jet skis, snowmobiles, ATV's, aircraft, hovercrafts or any other vehicle and/or purpose.

HYPERPRO steering dampers are FOR RACE USE ONLY, NOT FOR HIGHWAY USE!

Before installation:

- Please read the entire manual carefully before starting the installation!
- Check if you have all the tools required. Good tools are a must.
- Protect your bike at the most important places in and around the work area (e.g. tank, fairing, frame, etc.) with a blanket, towel or similar.

During installation:

- Check all operations and parts carefully before, during and after performing each step.
- Clean all surfaces that are required for fitting parts together or for applying self adhesives or loctite, thoroughly with contactcleaner or another degreaser, unless otherwise stated.
- Be carefull not to damage or scratch any part of your bike.
- ALWAYS work relaxed and concentrated!! It is very easy to damage something or make a mistake.

After installation:

- Check and make sure that there is no contact between any part of the steering damper kit and any part of the motorcycle. The kit should not hit anything. Steering movement should not be limited by the steering damper. If the steering movement is limited, adjust the position of the tube in the clamp untill steering movment is normal again. Do not forget to tighten the clamp bolt again!
- ALWAYS check the steering movement and feeling before each ride !
- FIRST RIDES: Start with the damper turned fully open (turn adjuster knob fully counter clockwise). Start adjusting in between rides with steps of MAX. 2 CLICKS (0.25 TURN) EACH TIME, untill the damper is working satisfactory for your riding style.
- NEVER USE MAXIMUM SETTING, ALWAYS OPEN AT LEAST 2 CLICKS (0.25 TURN).

- WARNING ! DAMPER HAS AN ACTIVE / SPEEDSENSITIVE DAMPING SYSTEM;
 - Steering with NORMAL MOVEMENT should be FREE !!
 - Steering with FAST MOVEMENT should be CONTROLLED BY DAMPER !!
- HYPERPRO uses a special seal to reduce friction. The seal uses an oil film to work properly. It is normal that some oil can appear on the pistonrod.
- Damper works with oil: DAMPING CAN BE HARDER AT LOWER TEMPERATURES!

Step 1: remove the fender & original steering damper

Step 2: modify the radiator guard

Remove the radiator guard from the bike. Modify the radiator guard by cutting and removing the part that is diagonally striped in the picture:



Step 3: install the mounting parts

Install the following mounting parts:

- Frame bracket (2)
- Washer M6 \varnothing 12 (3)
- O-Ring (4)
- Damper clamp (5)
- Bolt M6x20 Low head (6)

Put the parts together as shown on page 1. Apply loctite or similar to the bolt threads.

Mount the frame bracket (2) to the original mounting holes using the 2 original bolts. Tighten to the original torque setting (see service manual) or approx. 14-17Nm/124-150Lbs.In/10.3-12.5Lbs.Ft. Next, mount the washer (3), the O-ring (4) and the damper clamp (5) to the frame bracket (2) using the M6x20 low head bolt (6) and tighten to a torque of approx. 5-9Nm/44-80Lbs.In/4.0-6.4Lbs.Ft.

Step 4: install the steering damper

Install the steering damper using:

- Steering damper, stroke 68 REVERSED (7)

Ensure that the clamp bolt (5a) of the damper clamp (5) is pointing forward. Shove the damper (7), with the mount eye first, through the clamp until the ball joint can be fitted to the triple clamp mount. Use the original bolt (1), apply loctite and tighten to the original torque setting (see service manual) or approx. 14-17Nm/124-150Lbs.In/10.3-12.5Lbs.Ft.

Position the damper tube until the distance "X" stated on page 1 is reached, then tighten the M6 clamp bolt (5a) to a torque of approx. 6Nm/53Lbs.In/4.4Lbs.Ft.

Carefully Check if the damper does not touch anything (e.g. radiator) when steering from left to right. Check if the bike can make it's full steering angle from left to right. Modify distance X if necessary to improve fitment, do not forget to re-tighten the clamp bolt (5a) afterwards!

Step 5: install and lower the fender

Lower the bracket using:

- Fender lowering bracket (8)
- 2x Bolt M6x12 Button head (9)
- 2x Spacer (10)
- 2x Bolt M6x35 (11)
- 2x Bolt M6x16 (12)

Mount the fender bracket (8) to the fender using the M6x12 button head bolts (9). Tighten the bolts to a torque of approx. 5-9Nm/44-80Lbs.In/4.0-6.4Lbs.Ft.

Install the fender to the bike by fitting the lower M6x35 bolts (11) first, together with the supplied spacers (10). Then install the front M6x16 bolts(12) and tighten all the bolts to a torque of approx. 5-9Nm/44-80Lbs.In/4.0-6.4Lbs.Ft.

Check if the steering damper does not touch the fender when steering from left to right.